



**BATMAZ GROUP**  
INTERNATIONAL ARMS & SECURITY



# VERTICAL MAGAZINE FED SHOTGUN INSTRUCTION MANUAL

READ THE INSTRUCTIONS AND  
WARNINGS IN THIS MANUAL  
CAREFULLY BEFORE USING THIS FIREARM

**S A A M I**

SPORTING ARMS AND AMMUNITION MANUFACTURERS' INSTITUTE, INC.  
SINCE 1926



## GUN SAFETY RULES

Observe these rules of safe gun handling.

1. Always keep the muzzle pointed in a safe direction. Watch the muzzle at all times: never point a gun, accidentally or intentionally, at any person or anything you do not intend to shoot. identify the target before shooting; do not shoot at sounds.
2. Always treat any gun as if it is loaded - it may be!
3. Keep your finger off the trigger while operating the action and at all other times until you are ready to shoot.
4. Keep the safety "on" or in the "safe" position at all times until you are ready to fire the gun. Move to shoot. Up to the previous line after the word intend to shoot. Do not rely on your gun's safety, the safety on any gun is a mechanical device and is not intended as a substitute for common sense or safe gun handling.
5. Learn how your gun functions and handles. If you do not thoroughly understand the proper use and care of your gun, seek the advice of someone who is knowledgeable.
6. Do not alter or modify and parts of a firearm.
7. Store guns unloaded, separate from any ammunition, and where children cannot get to them.
8. Be sure the barrel is clear of any obstructions before loading. Make it a habit to check the barrel every time before loading.
9. Be sure you have and use the proper ammunition. A 20-gauge shell will enter a 12-gauge chamber far enough so that a 12-gauge shell can be loaded behind it. Also, a 3-inch shell may fit into a 2 3/4-inch chamber, but the crimp at the mouth of the shell will unfold into the forcing cone. If either of these things occur and you fire the gun, the gun will explode, damaging the gun and possibly causing serious injury or death to you and those around you.
10. Wear protective shooting glasses and adequate ear protection when shooting.
11. Never climb or jump over anything, such as a tree, fence, or ditch, with a loaded gun. Open the barrel, remove the shells, and hand the gun to a friend or place it on the ground on the other side of the obstacle before crossing it yourself. Do not lean a gun against a tree or other object; it could fall and possibly discharge.
12. Do not shoot at a hard surface or at water. Bullet and shot can ricochet or bounce off and travel in unpredictable directions with great velocity.
13. Never transport a loaded gun. Do not place a loaded gun into a vehicle. The gun should be unloaded and placed into a case when not in use.
14. Never drink alcoholic beverages before or during shooting.



## INTRODUCTION TO BATMAZ GROUP ARMS

For many of years, Batmaz Group Arms has been associated with the gun industry. After the word with modern technology and you have a product of true value and affordable quality. You have Batmaz Group Arms, we as Batmaz Group Arms thank you for the privilege of delivering a product to you that will provide you with years of pleasurable use. Happy shot gunning.

**ABOUT YOUR MAGAZINE FED SEMI-AUTOMATIC SHOTGUN** Your Batmaz Group Arms shotgun is gas operated.

The gas created from firing a live shot shell operates the action. Once the first shell has been fired, the next shell in the magazine will automatically cycle into the chamber, and this cycle will continue (each time the trigger is pulled) until all shells loaded in the magazine have been fired. The bolt will remain locked in the open position after the last shell is fired.

The technologically advanced gas metering system allows you to shoot 2 3/4 " and 3" shells interchangeably with any ammunition of the proper gauge for your shotgun with flawless performance. This and other fine features ensure that your shotgun will be a source of pride and pleasure for years to come. For 3 1/2" models the metering system allows you to shot heavy 2 3/4", 3" and 3 1/2" shells interchangeably.

**SAFETY SWITCH OR BUTTON** The safety is designed to stop the trigger mechanism.

**DON'T RELY ON YOUR GUN'S SAFETY. TREAT EVERY GUN AS IF IT WERE LOADED AND READY TO FIRE.** The safety on any gun is a mechanical device, and it is not intended as a substitute for common sense or safe gun handling. Always keep the muzzle pointed in a safe direction.

## GENERAL INFORMATION



1. Point the shotgun in a safe direction and keep fingers off the trigger and out the trigger guard.
2. Depress the magazine catch and remove the magazine.



3. Pull the bolt back and lock it to the rear by depressing the bolt hold open lever. Once the bolt is locked to the rear, both visually and manually inspect the chamber of the shotgun to confirm that the chamber is empty. Also check to make sure the magazine well is clear. Then cycle the bolt forward by pressing the bolt release lever.
4. Unscrew the front handguard secure cap and remove it.
5. Remove the Forearm.



6. After you remove the forearm, push " Cartridge Ramp Lock Button" and remove " Fixing Nut Barrel".
7. Remove the barrel to the rear slightly.



8. Remove the operating handle.



9. You are now ready to remove the bolt, bolt carrier and recoil spring. Remove this set to the rear slightly.
10. Further disassembly is not required for regular cleaning and maintenance.

### MECHANISM PARTS

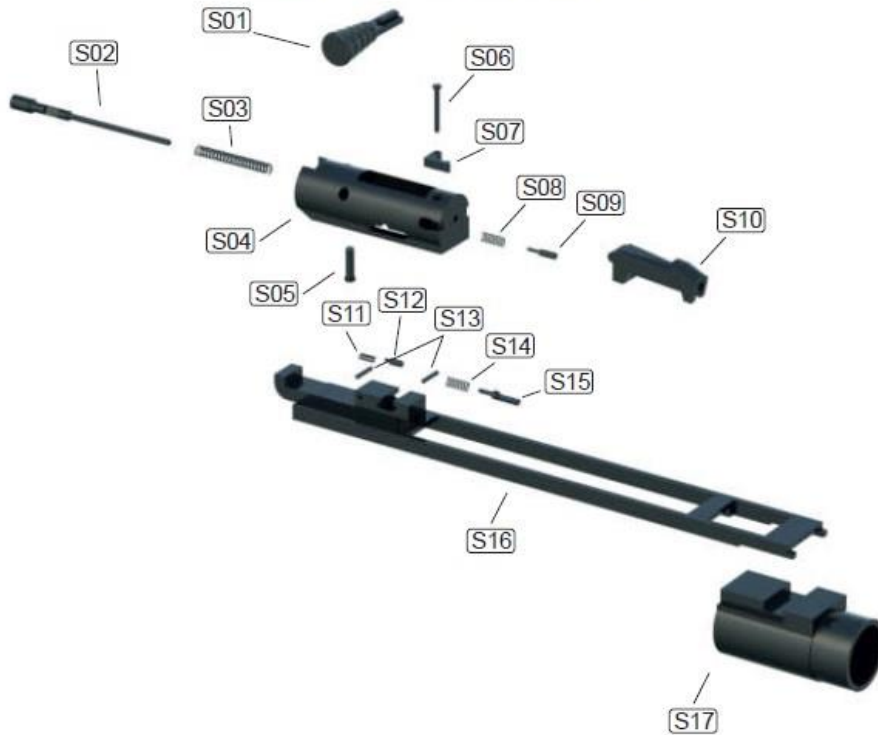

### STOCK&BOTTOM RECEIVER AND TRIGGER GROUP PARTS



# BARREL AND ASSEMBLY EQUIPMENT PARTS

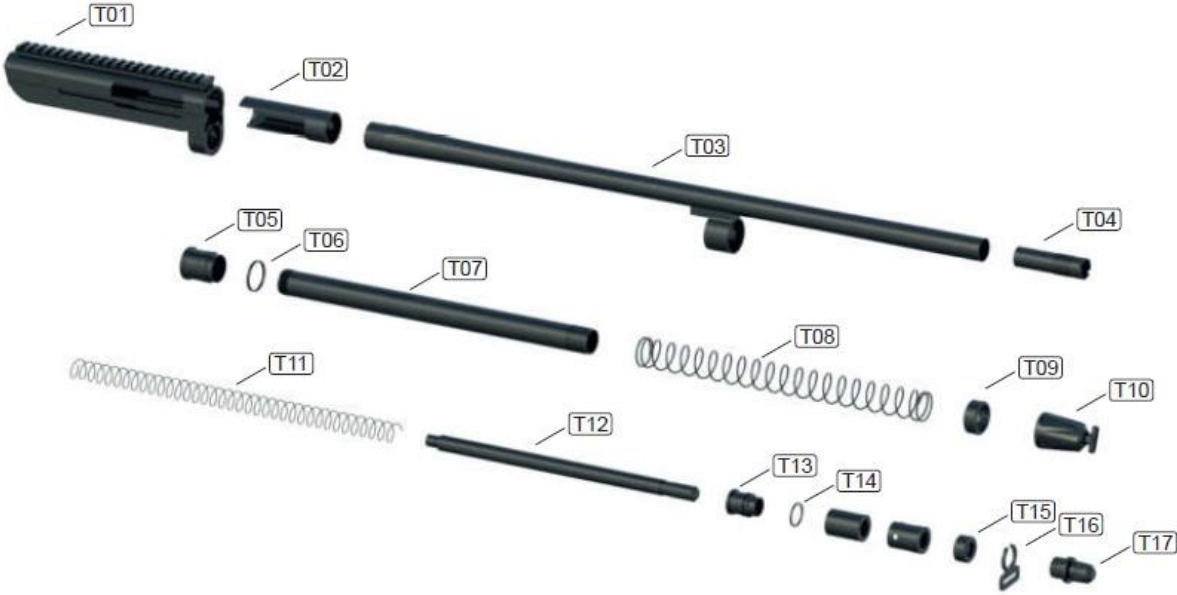

# STOCK SETS & MAGAZINE PARTS



## MECHANISM PARTS

S01 OPERATING HANDLE  
S02 FIRING PIN  
S03 FIRING PIN SPRING  
S04 MECHANISM  
S05 FIRING PIN CLAMP PIN  
S06 EXTRACTOR CLAMP PIN  
S07 EXTRACTOR  
S08 EXTRACTOR SPRING  
S09 EXTRACTOR BACK PIN  
S10 LOCK  
S11 OPERATING HANDLE LOCKING SPRING  
S12 OPERATING HANDLE LOCKING PIN  
S13 FIXING PIN  
S14 MECHANISM FIXING SPRING PIN  
S15 MECHANISM FIXING PIN  
S16 ACTION BAR  
S17 ACTION BAR SLEEVE

## STOCK&BOTTOM RECEIVER & TRIGGER GROUP PARTS LIST

H01 MECHANISM LOCK BREAK  
H02 CARTRIDGE LIFTER  
H03 BREAK LOCK ASSEMBLING PIN  
H04 BREAK LOCK SPRING  
H05 BREAK LOCK FIXED RECEIVER  
H06 SAFETY LINK  
H07 MAGAZINE LOCK  
H08 SAFETY LOCK PIN  
H09 SAFETY LOCK SPRING  
H10 SAFETY LOCK SET SCREW PIN  
H11 SYNTHETIC MAIN RECEIVER  
H12 CARTRIDGE LIFTER LOCK SPRING  
H13 CARTRIDGE LIFTER LOCK PIN (SYNTHETIC MODEL)  
H14 HAND GRIP BOTTOM COVER  
H15 HAMMER HOLDER  
H16 MAGAZINE LOCK PIN  
H17 HAMMER HOLDER SPRING  
H18 MAGAZINE LOCK BUTTON SPRING  
H19 MAGAZINE LOCK BUTTON  
H20 MAIN RECEIVER PINS  
H21 TRIGGER SPRINGS  
H22 TRIGGER  
H23 INSIDE TRIGGER  
H24 HAMMER SPRING  
H25 HAMMER

## STOCK SETS & MAGAZINE PARTS

P01 BUTT PAD  
P02 STOCK MAIN SCREW  
P03 REMOVEABLE STOCK  
P04 ASSEMBLY SCREW NUT  
P05 BUTT PAD FIXING SCREW  
P06 SLING SWIVEL NUT SCREW  
P07 SLING SWIVEL NUT PIN  
P08 SLING SWIVEL AREA  
P09 MONOBLOCK BOTTOM RECEIVER (SYNTHETIC MODEL)  
P10 FOREARM (SYNTHETIC MODEL)  
P11 ALUMINIUM FOREARM UPPER PART  
P12 REMOVEABLE SIDE PICATINNY  
P13 PICATINNY NUTS  
P14 PICATINNY FIXING SCREW  
P15 BARREL ASSEMBLY NUTS LOCKING EQUIPMENTS  
P16 BARREL ASSEMBLY NUTS  
P17 BARREL ASSEMBLY NUTS LOCKING EQUIPMENTS (ALUMINIUM FOREARM MODEL)  
P18 BARREL ASSEMBLY NUTS (ALUMINIUM FOREARM MODEL)  
P19 SLING SWIVEL NUTS  
P20 ALUMINIUM FOREARM ASSEMBLY NUTS  
P21 ALUMINIUM FOREARM BOTTOM PART  
P22 MAGAZINE SIDE EXTRACTOR SPRING  
P23 MAGAZINE SIDE EXTRACTOR NUT  
P24 MAGAZINE SIDE EXTRACTOR  
P25 MAGAZINE UPPER PLUG  
P26 2RD MAGAZINE

P27 5RD MAGAZINE  
P28 10RD MAGAZINE  
P29 2RD MAGAZINE SPRING  
P30 5RD MAGAZINE SPRING  
P31 10RD MAGAZINE SPRING  
P32 MAGAZINE BOTTOM PLUG LOCK NUT  
P33 MAGAZINE BOTTOM PLUG

## BARREL AND ASSEMBLY EQUIPMENT PARTS

T01 UP RECEIVER  
T02 BARREL LUG  
T03 BARREL  
T04 DOOR BUSTER  
T05 BIG PISTON  
T06 BIG PISTON ORING  
T07 LINK TUBE (SYNTHETIC FOREARM MODEL)  
T08 MAIN SPRING (SYNTHETIC FOREARM MODEL)  
T09 UPPER COVER (SYNTHETIC FOREARM MODEL)  
T10 ASSEMBLING NUT (SYNTHETIC FOREARM MODEL)  
T11 MAIN SPRING (ALUMINIUM FOREARM MODEL)  
T12 LINK TUBE (ALUMINIUM FOREARM MODEL)  
T13 SMALL PISTON  
T14 SMALL PISTON ORING  
T15 GAS DISCHARGE VALVE NUT  
T16 SLING SWIVEL NUT  
T17 ASSEMBLING NUT



## **STORAGE**

Clean thoroughly and oil your gun before storage. Store the gun in a case to prevent scratches and dents.

Store in a dry place to prevent corrosion. Store the gun away from children and in place where it cannot be obtained by those unauthorized to use it. Always store gun unloaded and separately from any ammunition.

## **IMPORTANT**

### **USAGE OF STEEL SHOT**

The choke (bore constriction) in all modern shotguns has been established based on the pattern performance of shot shells loaded with lead shot. When using the steel shot shells, you will notice a different performance in pattern density versus the established lead shot pattern, because the steel shot is harder and lighter than lead shot.

You should be aware of the following differences and cautions: Never shoot steel shot loads in a full choked barrel or full choke tubed barrel. To do so may cause the barrel to swell or rupture. In general, steel shot fired with a modified choke will produce the equivalent of a lead full choke pattern. This will be true of all steel shot sizes up to and including no. 2. The established improved cylinder chokes will produce the equivalent of a (lead) modified choke pattern. All steel shot sized larger than no. 2, and including special sized such as -F-, "T", etc., should be used only with improved cylinder chokes. These steel shot sized, when used in improved cylinder chokes, will produce patterns equivalent to (lead) full choke patterns. The established cylinder choke or bore will produce the equivalent of a modified (lead) pattern. Additional information concerning the use of steel shot is available from Remington, Winchester, Federal and other ammunition companies.

## **PARTS**

To order parts, please furnish the following information: Your name, address, telephone number, firearm serial number, make and model. When we receive your request we will send you an order form and a parts breakdown with prices.

## **MAINTENANCE AND CLEANING**

Caution: Make sure the gun is unloaded.

1. Make sure that the broad, polished, finely fitted mating surfaces of the breech block and receiver are especially clean and lightly oiled with a high quality gun oil. Do not use pure silicone or lanolin.
2. Run an oil patch through the bore with a cleaning rod starting from the breech end. To prevent leading, use a cleaning solvent and brass brush to clean the bore periodically. Follow this cleaning with one or two clean oil patches. Important: If your gun is equipped with choke





tubes, do not use a brass brush to clean the barrels unless a choke tube is installed in **each** barrel. Barrels that utilize choke tubes must also have the choke tubes removed to clean and oil the threads inside the barrel and the choke tubes themselves. This will protect the threads from being damaged by cleaning tools and also prevent a dirt build up that would cause the choke tube to become difficult to remove from the barrel. Damage can result to choke tubes and barrel when attempting to remove sticky choke tubes.

Never fire your gun without choke tubes snugly tightened in barrels. Do not over tighten choke tubes. Wipe all exposed metal surfaces with an oiled cloth before storing.





## WARRANTY CARD

PURCHASER \_\_\_\_\_

Street \_\_\_\_\_

City \_\_\_\_\_ State \_\_\_\_\_ Zip \_\_\_\_\_

Phone \_\_\_\_\_

Purchase Date \_\_\_\_\_

PRODUCT: Model \_\_\_\_\_ Gauge \_\_\_\_\_ Serial # \_\_\_\_\_

SIGNATURE \_\_\_\_\_

Please sign and return this card to validate warranty

## BE COURTEOUS

When shooting or hunting always acquire the permission of the landowner. Respect the land. Don't litter the area. Drive vehicles only where advance permission has been granted and always express gratitude for use of another person land. Remember you are helping and developing a reputation for all sportsmen/sportswomen.



**BATMAZ GROUP**  
INTERNATIONAL ARMS & SECURITY

## BATMAZ GROUP DIŐ TİCARET VE PAZARLAMA

Address: Yeni Mah. 40657. Sok. No 29/4 BeyŐehir, Konya TURKEY

Web: <https://www.batmazgroup.com/>

Email: [export@batmazgroup.com](mailto:export@batmazgroup.com)

